

# CHAMBERLAIN®



## CAUTION

ACTIVATE THE TRANSMITTER ONLY WHEN THE DOOR / GATE IS IN FULL VIEW, FREE OF OBSTRUCTION AND PROPERLY ADJUSTED. NO ONE SHOULD ENTER OR LEAVE THE DOOR/ GATE WHILE IN MOTION. DO NOT ALLOW CHILDREN TO OPERATE THE REMOTE(S) OR THE DOOR/ GATE CONTROL BUTTONS. DO NOT ALLOW CHILDREN TO PLAY NEAR THE DOOR/ GATE.

The TriCode™ digital TC1 and TC2 transmitters are a single-channel and dual-channel wireless radio control designed for use with automatic garage/gate operators and access control systems. All TriCode™ products may be combined with Linear/Delta-3™, Multi-Code™, and Stanley™ radio products.

The TriCode™ radio format provides a potential of 1024 different digital codes. For Linear/Delta-3™ compatible products, 256 different digital codes are available. The codes are set using a 10-position DIP switch system.

## TriCode™ Transmitters

### TC1 Single Channel Transmitter

U.S. Patent Pending



### TC2 Dual-Channel Transmitter

U.S. Patent Pending

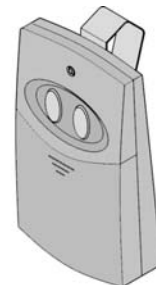

This device complies with FCC Rules Part 15 and IC Canada Rules and Regulations. Operation is subject to the following two conditions: (1) This device may not cause harmful interference and (2) this device must accept any interference received, including interference that may cause undesired operation.

F.C.C. rules prohibit adjustments to or modification of receiver and/or remote control transmitter circuitry except for changing the code setting and replacing remote control transmitter battery. **THERE ARE NO OTHER SERVICEABLE PARTS.**

## SWITCH SETTINGS

**CAUTION:** To avoid possibility of duplicating codes in adjacent systems, all transmitters and receivers should be re-coded prior to operation. Unless using maximum number of codes the following four codes should not be used:

- All DIP Switches ON
- All DIP Switches OFF
- DIP Switches alternating ON/OFF
- DIP Switches alternating OFF/ON.

### Step 1 Locate Switch(s) and Connect Battery

Locate the DIP switch, configuration switch and battery by sliding down access cover on front of the transmitter case. DIP switch is numbered 1 through 10. The configuration switch is located to the right of the DIP switch (Refer to figures 1, 2, 3 and 4).

The battery is located below the switches. Connect the battery connector to the 9V battery before programming transmitter (Refer to figure 3).

### Step 2 Set Transmitter Configuration Switch(s)

The TriCode™ Transmitter is factory set to Linear/Delta-3™ position.

Using a pointed object set transmitter configuration switch to desired setting (Refer to figure 1). On dual channel transmitters the left button corresponds to the top set of switches and the right button corresponds to the bottom set of switches (Single Channel, Refer to figure 3; Dual Channel, Refer to figure 4).

### Step 3 Set Transmitter DIP Switch(s)

The TriCode™ Transmitter DIP switch(s) are factory set, CH1 OFF (1-10) and CH2 ON (1-10).

Using a pointed object set transmitter DIP switch to desired setting. For Linear/Delta-3™ compatibility, set codes on switches 1 through 8. Switches 9 and 10 are not used for Linear/Delta-3™ products, and can be in either the "ON" or "OFF" setting.

**Note:** Switches in receiver must match the switches in all transmitters used to operate the receiver. Some older radios use toggle switches and it may be difficult to determine 'ON' & 'OFF'. If so, try reverse settings on the TriCode™.

## Step 4 Test the Equipment

If not already installed, connect the receiver to the operator as described in their installation instructions.

**Be sure the door/gate area is clear of people and obstructions.** Activate the transmitter button to verify that the receiver Relay “clicks” & the opener activates.

If the receiver relay does not “click” verify power connection to receiver. Then review configuration & DIP switch settings in both devices.

If receiver “clicks” but opener doesn’t activate, review connection between receiver & opener verifying relay out to the matching relay in (See figure 4).

## Battery Replacement

The 9 volt battery should last 12 to 18 months of normal use. The green LED on the face of the transmitter will light dimly or not at all when the battery needs replacing. The battery is located under the access cover.

FIGURE 1

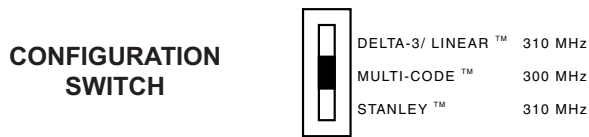

FIGURE 2

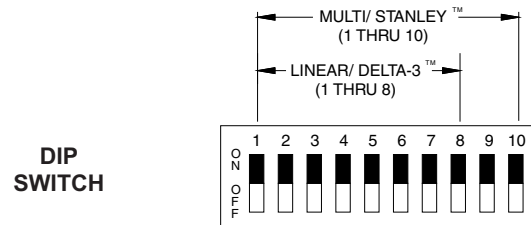

FIGURE 3

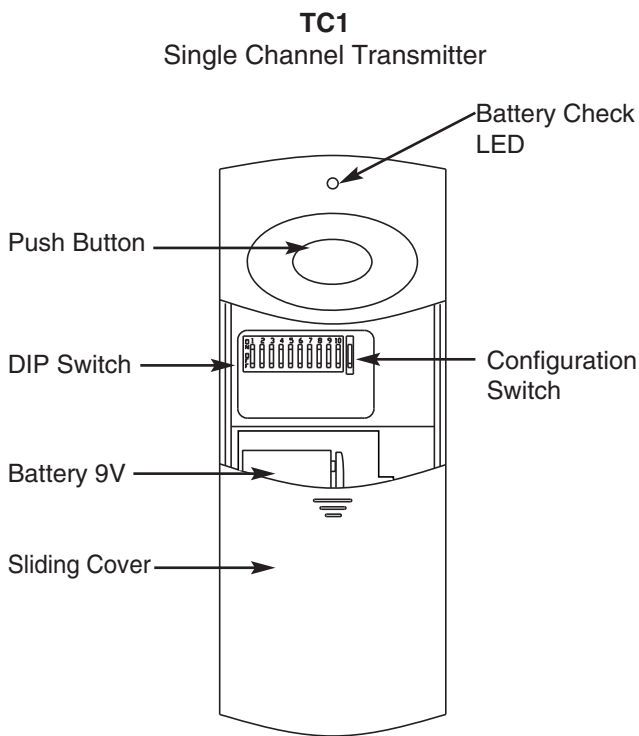
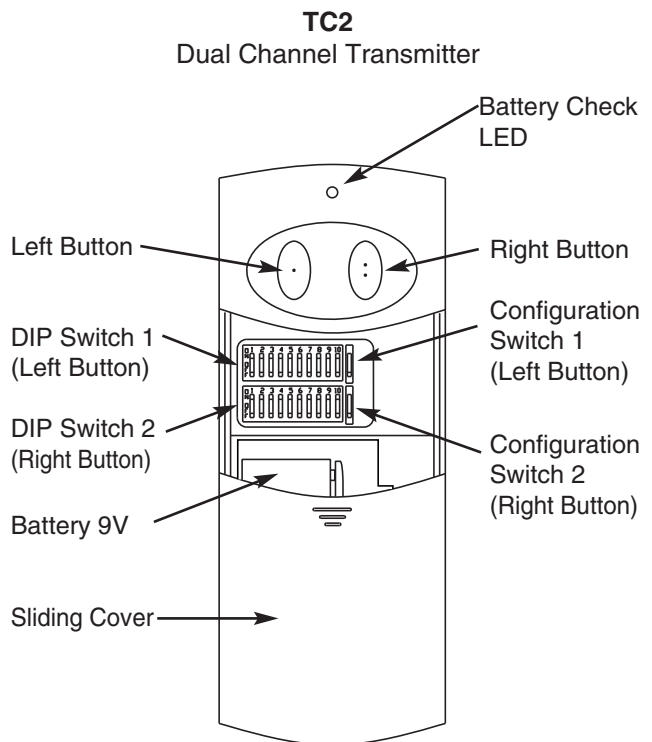

FIGURE 4



INSTALLATION AND SERVICE INFORMATION ARE AVAILABLE  
 6 DAYS A WEEK CALL OUR TOLL FREE NUMBER  
 1-800-528-3536  
 HOURS 7:00 TO 3:30 p.m. (Mountain Std. Time)  
 MONDAY Through SATURDAY  
 OR CONTACT US THROUGH THE WEB AT  
 WWW. CHAMBERLAINGROUP.COM