



655 Eisenhower Drive
Owatonna, MN 55060 USA
Phone: (507) 455-7000
Tech. Serv.: (800) 533-6127
Fax: (800) 955-8329
Order Entry: (800) 533-6127
Fax: (800) 283-8665
International Sales: (507) 455-7223
Fax: (507) 455-7063
Website: www.otctools.com

Form No. 563729

Operating Instructions
for:

4744

Chain Breaker and Riveting Tool Kit

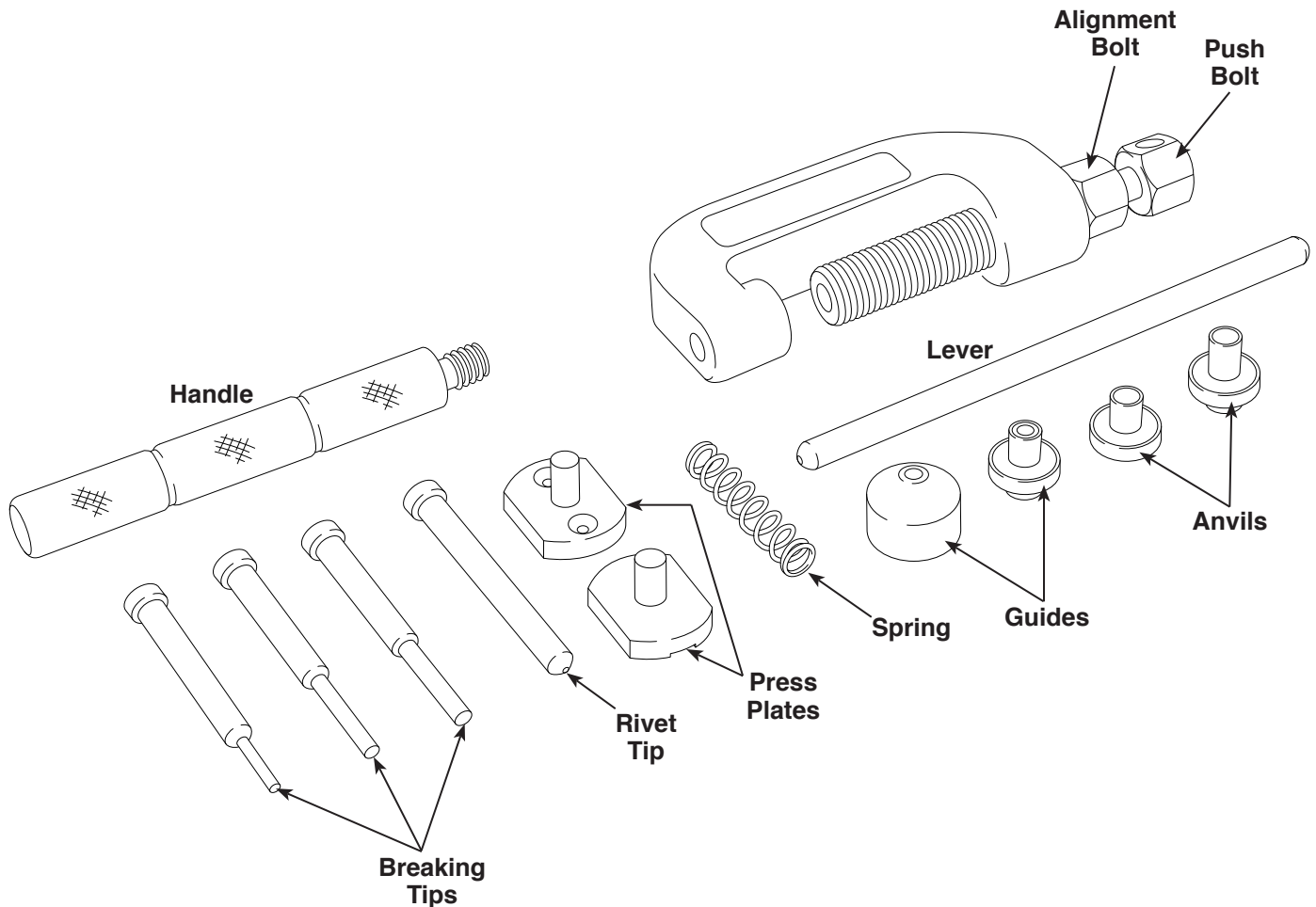

Safety Precautions



CAUTION: To prevent personal injury, wear eye protection that meets ANSI Z87.1 and OSHA standards.

CAUTION: To prevent equipment damage,

- Do not use power tools or extensions with these tools. Hand tighten only.
- Clean the tools and lubricate threads before each use.
- Grind the rivet head on No. 520 and greater chains.

Sheet No. 1 of 1

Issue Date: Rev. B June 16, 2014

Breaking Chains

1. Thread the alignment bolt into the C-frame.
2. Choose the breaking tip that fits your application. Insert the breaking tip into the spring, and slide them both into the alignment bolt.
Note regarding the 2.2 mm breaking tip: Thread the upper guide into the alignment bolt and place the lower guide in the hole in the C-frame body. See Figure 1.
3. Thread the push bolt into the alignment bolt above the tip.
4. Position the tool over the chain with the breaking tip aligned with the chain pin.
5. Tighten the push bolt by hand using the lever or a 14-mm wrench. Tightening the push bolt pushes the chain pin completely out of the chain and through the hole in the C-frame.

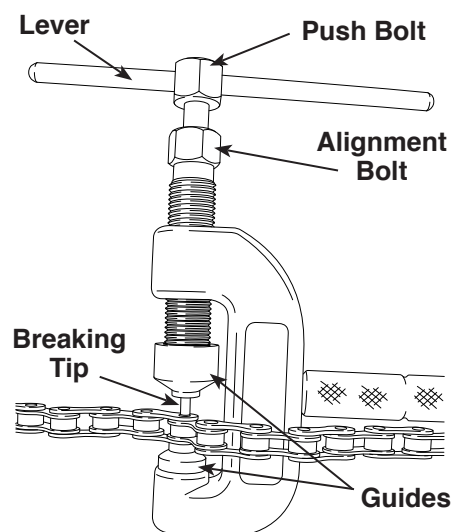

Figure 1
2.2 mm Application

Pressing Side Plates

1. Thread the alignment bolt into the C-frame.
2. Assemble the press plates into the tool. Place the grooved press plate into the hole in the C-frame; insert the other press plate into the alignment bolt.
3. Verify the chain pins are aligned with the groove and holes in the press plates.
4. Use a 14-mm wrench to tighten the alignment bolt until chain pins protrude past the face of the side plate.

Clip-type Master Links

The pins must protrude enough to install the clip into the grooves in the chain pin.

Rivet-type Master Links

The pins must protrude enough to be flared over the side plate.

Refer to the chain manufacturer's specifications for chain pin protrusion as well as the direction and installation of master link clips.

Riveting Chain Pins

1. Thread the alignment bolt into the C-frame.
2. Insert the rivet tip into the spring and slide them both into the alignment bolt.
3. Thread the push bolt into the alignment bolt above the tip.
4. Place the large anvil in the hole in the C-frame.
5. Place the tool over the chain pin to be riveted, with the hollow end of the chain pin facing the rivet tip.
Note: The small anvil is used for cam chains up to the 3-series.
6. Verify the rivet tip is withdrawn enough to clear the end of the chain pin.
7. Tighten the alignment bolt securely against the side plate of the chain pin.
8. Tighten the push bolt by hand using the lever or a 14-mm wrench until the rivet tip spreads the hollow nose of the chain pin. Now the end of the chain pin should be flared over the side plate just enough so the side plate is solidly held in place. Repeat this procedure on the other chain pin.
9. Remove the tool from the chain. Verify both chain pins show the same size flares. Verify the riveted-on side plate is aligned with the side plates of the adjacent chain links.